

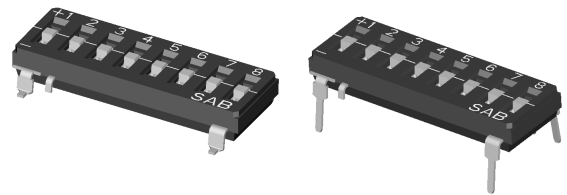

Features

- ◆ Twin contact designed to ensure stable contact.
- ◆ Highly resistant to physical shock & vibration.
- ◆ All materials are UL 94V-0 grade, high temperature resistant plastic.
- ◆ Top tape sealed for L type to ensure washable.
- ◆ Smaller size to save space by reducing the volume to 41% or 67% of standard type.
- ◆ Tri-State(+,0,-) setting function.
- 8 poles=(3^8)=6,561 codes
- 10 poles=(3^{10})=59,049 codes
- ◆ Light click feeling.



DTS

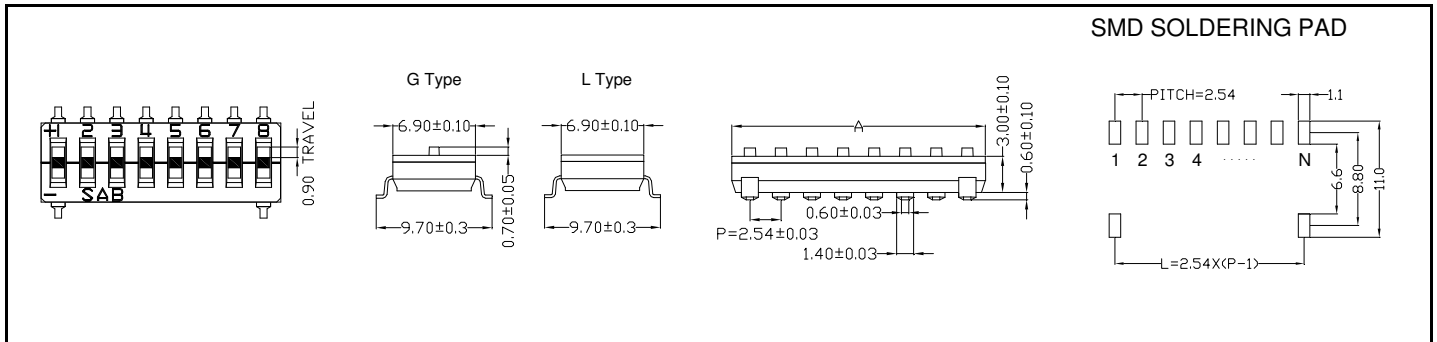

DTA/H

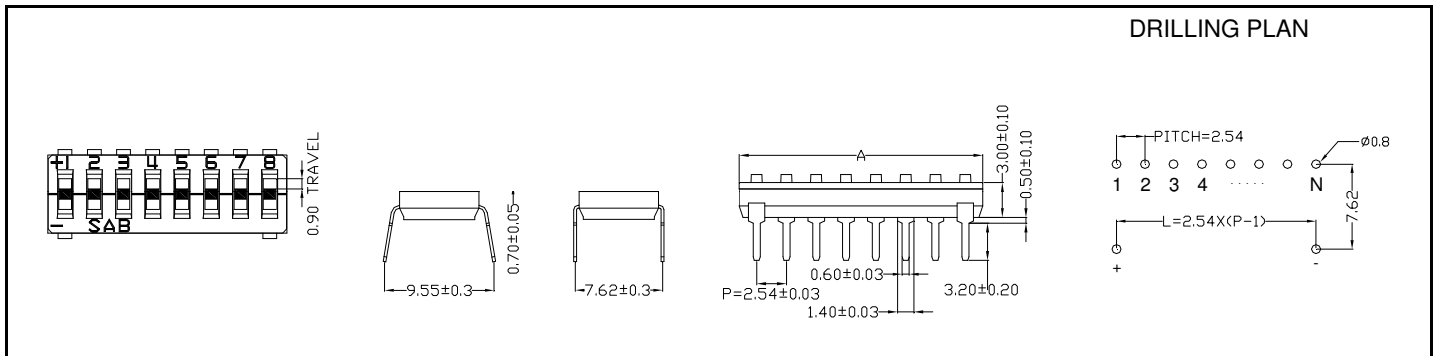

Specifications

- ◆ **Contact Rating**
Switching 25mA,24VDC
Non-Switching 100mA,50VDC
- ◆ **Contact Resistance**
Initial 50mΩ Max.
After Life Test 100mΩ Max.
- ◆ **Insulation Resistance** 100MΩ min at 500VDC
- ◆ **Dielectric Strength** 500VDC/1 minute
- ◆ **Operating Force**..... 1,000g Max.
- ◆ **Mechanical Life**..... 3,000 cycles
- ◆ **Electrical Life**..... 2,000 cycles

Materials

- ◆ **Cover & Base:** High Temperature UL 94V-0 Thermoplastic, Black.
- ◆ **Actuator:** High Temperature UL 94V-0 Thermoplastic, White.
- ◆ **Terminal & Movable Contact:** Copper Alloy with Gold Plated or Pure-Tin.
- ◆ **Terminal:** Copper Alloy with Gold Plated or Pure-Tin.
- ◆ **Tape Sealed:** Polyimide film.

Wiring Diagram

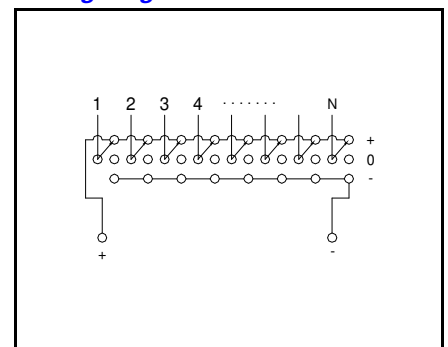

Soldering Information

- ◆ **Hand Soldering**
Soldering Iron 30W(or under) at 350°C/3 sec. Max.
or at 270°C/5 sec. Max.
- ◆ **Wave Soldering**
Temperature: 260°C 10 sec. Max.
- ◆ **Reflow Soldering.**
260°C ±5°C within 30 sec. In-line or Batch system.
- ◆ L & G Type: un-washable & un-accept reflow process.

Packaging Information

- ◆ All DIP switches are shipped in Tube.
- ◆ DTS can be packed by Tape & Reel.
- ◆ Actuators all in "OFF" position.
- ◆ Keep all actuators in "OFF" position during soldering and cleaning process.

Order Information

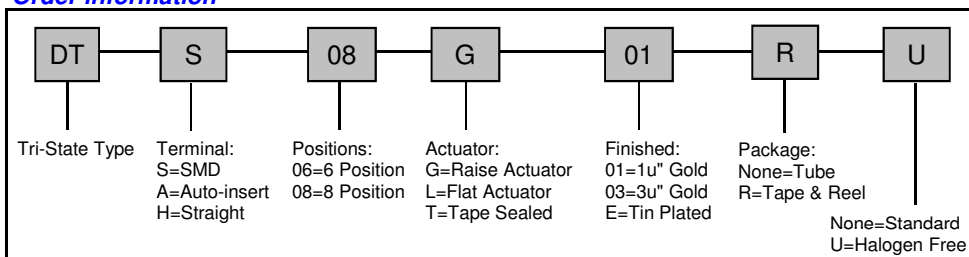

Package

P/N	No. Of Pole	Dim. A	Quantity per Tube
DTS/A/H02	2	5.52mm	95
DTS/A/H03	3	8.06mm	65
DTS/A/H04	4	10.60mm	48
DTS/A/H06	6	15.68mm	33
DTS/A/H07	7	18.22mm	28
DTS/A/H08	8	20.76mm	25
DTS/A/H09	9	23.30mm	22
DTS/A/H10	10	25.84mm	20
DTS/A/H12	12	30.92mm	17