

# WATER PROOF SWITCHES



## SW1 (IP67) SERIES

### DIMENSIONS

Unless otherwise specified, a tolerance of  $\pm 0.4\text{mm}$  applies to all dimensions.

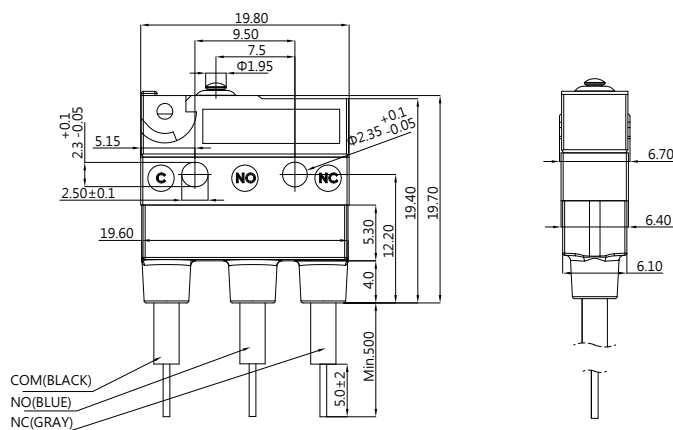

### APPLICATIONS

Telephone, Air conditioner, Computer, Humidifier, Alarm, Time recorder, Mixer & Chopper, Solder gun, Neon phone, Fax machine, Joystick, Water pump, Gas detector, Pencil sharpener, Money sorter, Food processor, Electric knife, Toy car, Juice maker, Electric steak pan.

### THE SELECTION OF RATING & FORCE

| MODEL | Rating | L | S | H |
|-------|--------|---|---|---|
| SW1   | 0.1A   | * | * | * |
|       | 6 A    | * | * | * |
|       | 10A    |   | * | * |
|       | 12A    |   |   | * |

NOTE : The Symbol " \* " to represent the result is accepted

### RATING

0.1A 125/250VAC  
 6A 125/250VAC , 5A 30VDC  
 10A 125/250 VAC , 5A 30VDC  
 12A 125/250 VAC , 5A 30VDC

### ORDERING INFORMATION

