

CIRCUIT DIAGRAM

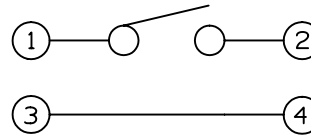

P.C.B LAND DIMENSION

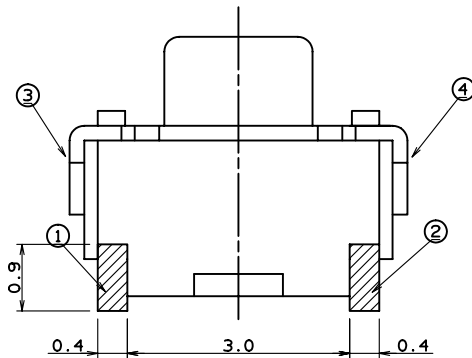
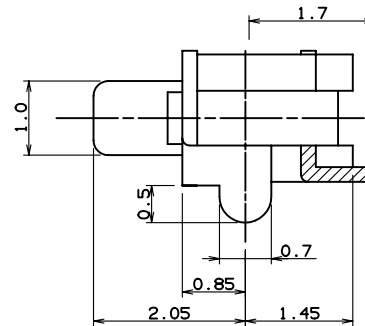
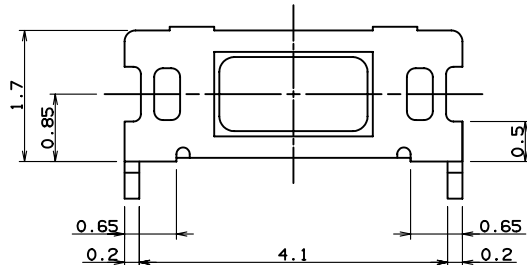
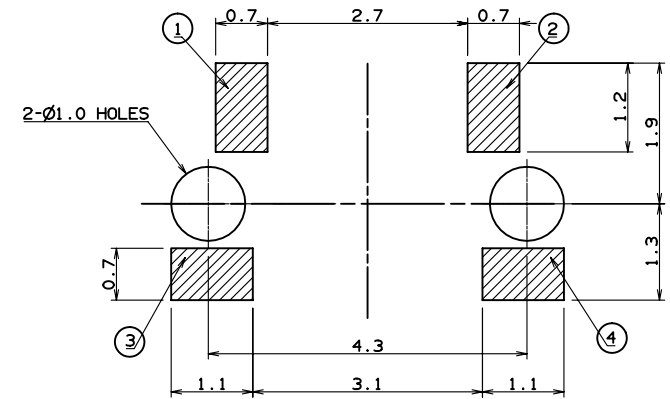

NOTES

1. RATING : DC 12V / 20mA Max
2. CIRCUIT : 1C - 1P
2. CONTACT RESISTANCE : 100mΩ MAX
3. STROKE : 0.2 ± 0.1mm
4. OPERATING FORCE : 160 ± 50gf
5. OPERATING LIFE : 100,000 TIMES
6. NON SPECIFIED DIMENSIONS
TOLERANCE : ± 0.2mm

No.	PART NAME	Q'TY	MATERIAL	SIZE	TREAT.	REMARKS
△			3RD ANGLE PROJECTION	UNIT m/m	SCALE 1	MODEL MT 1100A
△			APPROVED	CHECKED	DESIGNED	DWG. NAME ASS'Y DIAGRAM
△						DWG. NO.
NO.	DATE	NOTE	SIGN			