

P.C.B DIMENSION

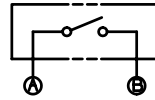

CIRCUIT DIAGRAM

NOTE

1. OPERATING FORCE : 160 ±50gf
2. TRAVEL : 0.25 +0.2/-0.1 mm
3. CONTACT RESISTANCE : 100 mΩ Max
4. GENERAL TOLERANCE : ±0.3

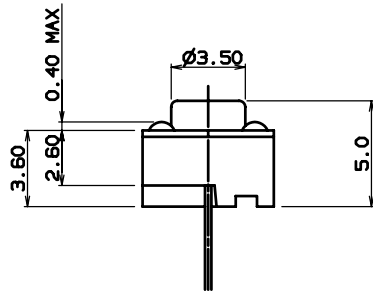
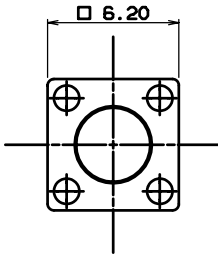

\* PACKING QUANTITY : 1,000 PCS

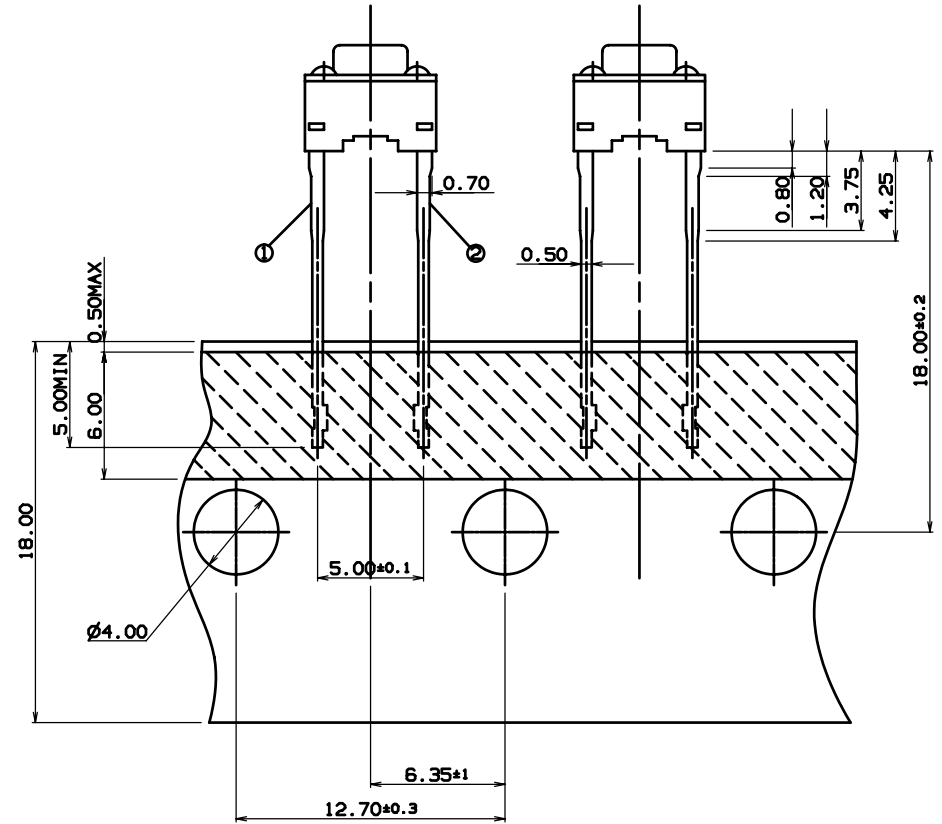
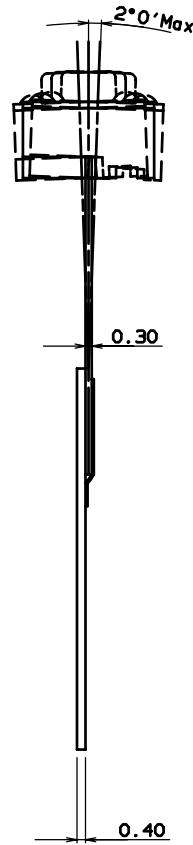

NO	PART NAME	Q'TY	MATERIAL	REMARK
1	CASE	1	NYLON66 G30	BLACK
2	STEM	1	NYLON66 G30	BLACK
3	COVER	1	PET	
4	TERMINAL	1	C2680R-EH	Ag 0.5μ
5	CONTACT	1	C5210R-EH	Ag 0.5μ

No.	PART NAME	Q'TY	MATERIAL	SIZE	TREAT.	REMARKS
5						
4						
3						
2						
1						
NO.	DATE	NOTE	SIGN			

3RD ANGLE PROJECTION	UNIT m/m	SCALE	MODEL MT 1102RA-2
APPROVED	CHECKED	DESIGNED	DWG. NAME ASS'Y DIAGRAM
			DWG. NO.