

MT1102-2 STANDARD COLOR

MODEL	"L"	∅ I	COLOR	STEM MATERIAL
MT1102	4.3	3.5	BLACK	NY66
MT1102A	5.0	3.5	BLACK	NY66
MT1102B	9.5	3.15	BLACK	PBT
MT1102C	8.0	3.2	WHITE	PBT
MT1102D	13.0	2.9	BLACK	PBT
MT1102E	7.3	3.25	IVORY	PBT
MT1102F	7.0	3.3	BLACK	PBT
MT1102G	8.5	3.15	BLACK	PBT
MT1102I	17.0	2.8	BLACK	PBT
MT1102K	12.5	2.9	BLACK	PBT

MODEL	O/F FORCE	COLOR
MT1102	100gf	BROWN
MT1102-1	130gf	GRAY
MT1102-2	160gf	
MT1102-3	250gf	RED

P.C.B DIMENSION

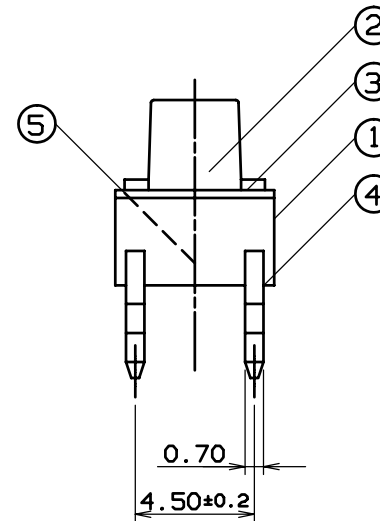
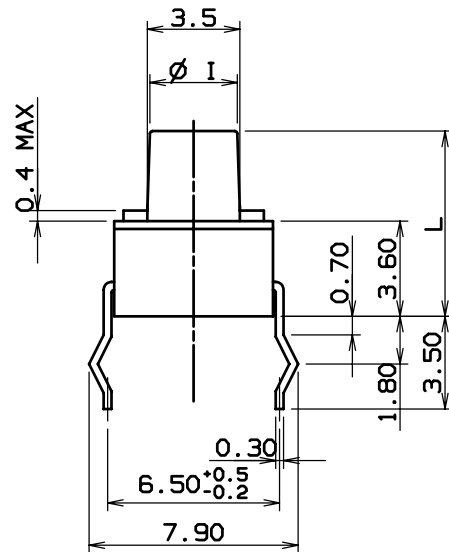
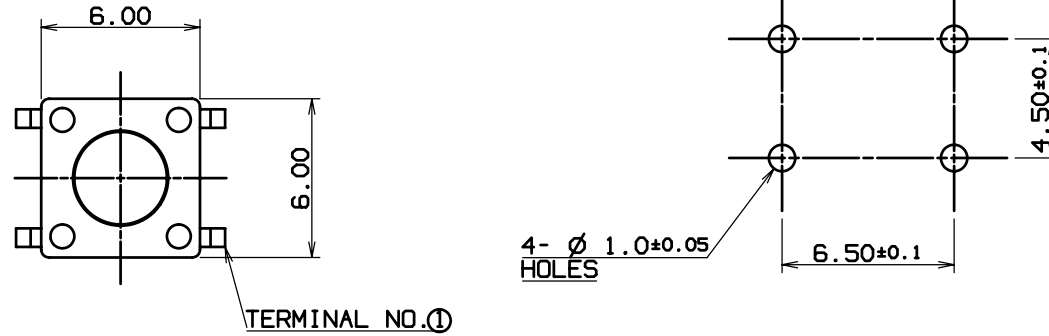

CIRCUIT DIAGRAM

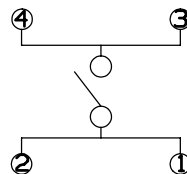

NOTE

1. TRAVEL : 0.25 +0.2/-0.1 mm
2. CONTACT RESISTANCE : 100mΩ Max
3. GENERAL TOLERANCE : ±0.3

6. PART LIST

NO	PART NAME	Q'TY	MATERIAL	RAMARKS
①	CASE	1	NYLON66 G30	
②	STEM	1	NY66 G30, PBT	
③	COVER	1	PET	
④	TERMINAL	1	C2680R-EH	Ag plate
⑤	CONTACT	1	C5210R-EH Ag clad 0.5μ	

No.	PART NAME	Q'TY	MATERIAL	SCALE	MODEL	TREAT.	REMARKS
⑤				3RD ANGLE PROJECTION	UNIT		
④				APPROVED	m/m	DESIGNED	MT 1102 SERIES
③				L.Y.B	CHECKED	K.Y.G	DWG. NAME
②							ASS'Y DIAGRAM
①							DWG. NO.
NO.	DATE	NOTE	SIGN				