

CIRCUIT DIAGRAM

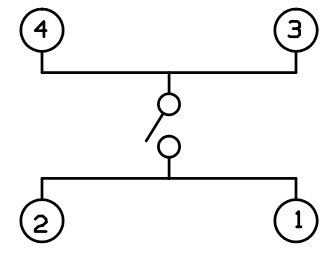

P.C.B DIMENSION

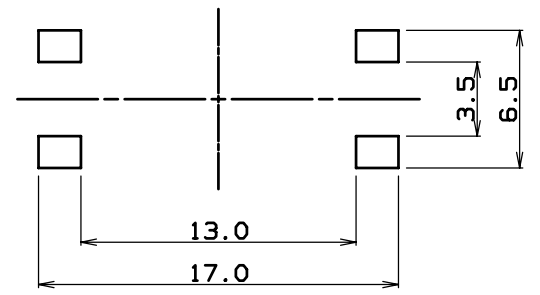

NOTE

- 1. RATING : DC 12V, 50mA
- 2. CONTACT RESISTANCE: 100mΩ Max
- 3. OPERATING FORCE: 160±50gf
- 4. TRAVEL : 0.3±0.15 mm
- 5. GENERAL TOLERANCE: ±0.3

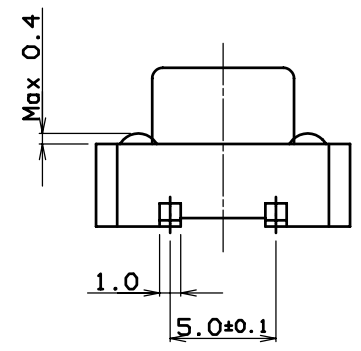
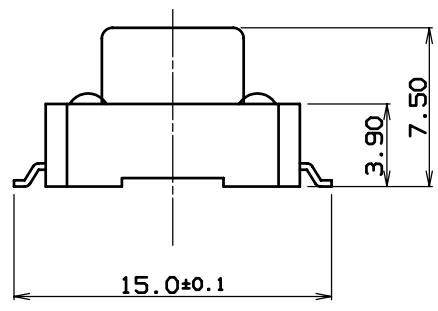

NO	PART NAME	Q'TY	MATERIAL	REMARK
1	COVER	1	SPTe	
2	STEM	1	PA6T	IVORY
3	CASE	1	PA6T	IVORY
4	TERMINAL	1	C2680R-EH	Ag PLATE
5	CONTACT	1	C5210R-EH	Ag 0.5μ

No.	PART NAME	Q'TY	MATERIAL	SIZE	TREAT.	REMARKS
③			3RD ANGLE PROJECTION	UNIT	SCALE	MODEL
④			APPROVED	m/m	DESIGNED	MT 1106SB-2
⑤						DWG. NAME
⑥						ASS'Y DIAGRAM
⑦						DWG. NO.
NO.	DATE	NOTE	SIGN			